



Montgomery County Residential Deck

Montgomery County Residential Deck Construction Standards Quality Standards for building decks in residential areas.

General Notes

1. The use of this package, in lieu of construction plans, applies to **typical rectangular shaped decks** which are **single span, single level decks only** (Figure 1).

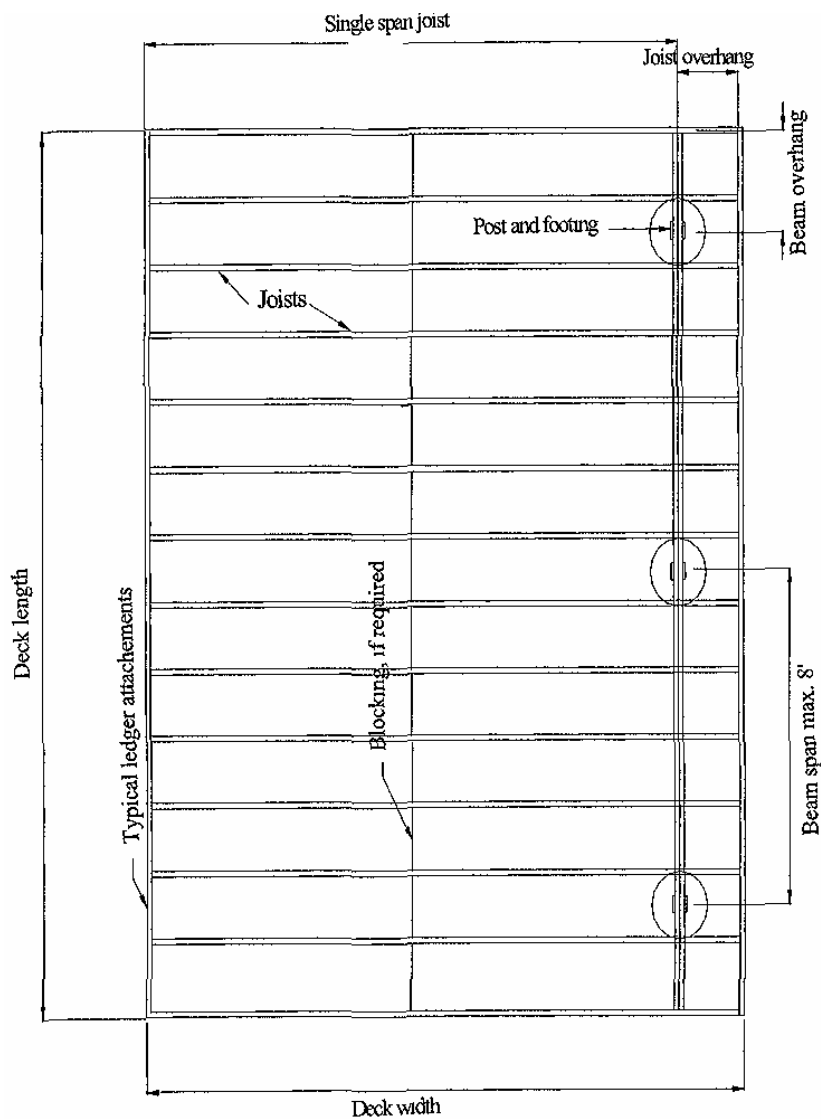

Figure 1: Framing plan for an attached deck

2. Decks constructed according to this handout are not approved for future hot tub installations.
3. Decks shall not be attached to house overhangs, bay windows, or chimneys.
4. Deck shall not be loaded with more than 50 psf (pounds per square foot) total load. Soil bearing capacity shall be minimum 2000 psf and the minimum compressive strength of concrete shall be 2500 psi (pounds per square inch).
5. All deck lumber shall be #2 Southern Pine or better. Lumber shall be pressure-treated in accordance with the above ground and ground contact standards issued by the American Wood-Preservers' Association (APWA).
6. Above grade fasteners shall be hot-dip galvanized steel with a minimum coating of 2 ounces of zinc per square foot, according ASTM A 153, or stainless steel. Proprietary thin-plate connectors shall be hot-dip galvanized steel with a minimum coating of 1.85 ounces of zinc per square foot, according ASTM A 653, or stainless steel. Screws, spirally grooved and ring shanked nails shall be used for the deck surface and only manufacturer-specified fasteners shall be used to attach the connectors. Do not mix galvanized and stainless steel connectors.
7. Decks 30 inches or less above grade are not required to have a guardrail.
8. A copy of **this document is required to be on the jobsite and available for inspection.**

Framing Decks

The decking boards are supported by joists that are supported by beams. The beams transfer the loads to posts wherefrom the loads are transferred to footings and ground. The deck can be attached to the house or freestanding. If the deck is attached to the house, a ledger and fasteners are used to support that end of the deck. If the deck is freestanding, the structural support near the house is provided by an additional row of beams and posts. Bracing is used to provide the load path for lateral loads.

I) Decking Boards

Decking laid perpendicular to joists may consist of 2x6 inches structural lumber supported by joists spaced at maximum 24 inches or 5/4 radius edge decking supported by joists spaced at maximum 16 inches. Manufactured decking systems (plastic, fiberglass, etc.) must be listed by an approved code agency in a current evaluation report.

II) Joists and Beams

Maximum joist span lengths are shown in Table 1. Joists may overhang not more than 3 feet; however, all overhangs require a minimum joist span length of 6 feet (Figure 2).

Maximum beam span is 8 feet. Beam sizes are shown in Table 1. The beams may overhang a maximum of 2 feet past the centerline of the outside post (Figure 3). Beams must span continuously between posts and shall be spliced at interior post locations only.

Spans are measured between the centerline of bearings or supports.

Table 1:

Joists				Beams	
Size	Spacing	Maximum Spans	Overhang	Size	with Overhanging Joists
2x6	12"	10'-4"	2'-6"	2-2x8	2-2x10
	16"	9'-5"	2'-6"	2-2x8	2-2x10
	24"	7'-8"	2'	2-2x8	2-2x10
2x8	12"	13'-6"	3'	2-2x10	2-2x12
	16"	12'-2"	3'	2-2x10	2-2x10
	24"	10'	2'-6"	2-2x8	2-2x10
2x10	12"	17'-5"	3'	2-2x10	2-2x12
	16"	15'-8"	3'	2-2x10	2-2x12
	24"	12'-9"	3'	2-2x10	2-2x12
2x12	12"	20'-10"	3'	2-2x12	3-2x10
	16"	18'-3"	3'	2-2x10	2-2x12
	24"	15'-1"	3'	2-2x10	2-2x12

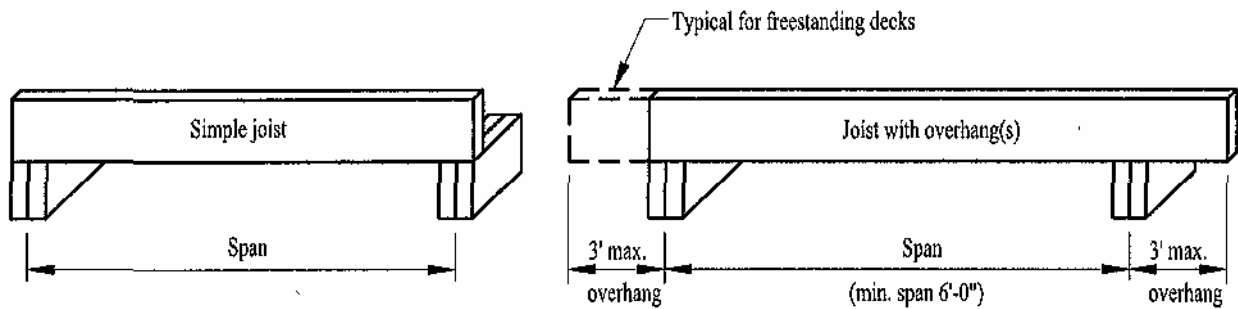

Figure 2: Joist Span Types

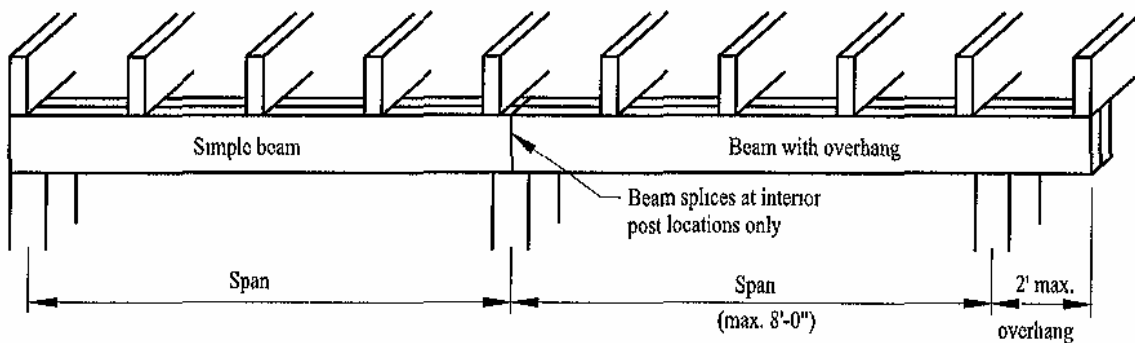

Figure 3: Beam Span Types

III) Posts

All posts shall be 4x4 inches up to a height of 8 feet and 6x6 inches beyond that. However, maximum post height is limited to 10 feet. It is recommended to use 6x6 inches posts in all situations because they are stronger and more durable than 4x4 inches posts. The height of the post is measured from the footing to the post attachment to the beam (Figure 4).

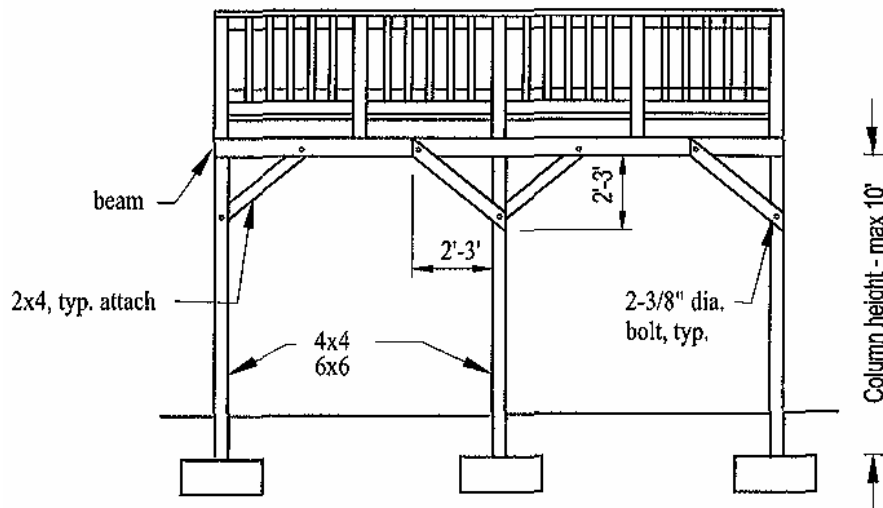

Figure 4: Deck posts

IV) Footings

Footings shall be minimum 20 inches square or 22 inches diameter (Figure 5). Bottom of footings shall be a minimum of 24 inches below grade and shall bear on solid ground. For freestanding decks, the footings close to the house must be installed as shown in Figure 6. Distances to the edges to the footing and embedment of connectors must be in accordance with the manufacturer's recommendations.

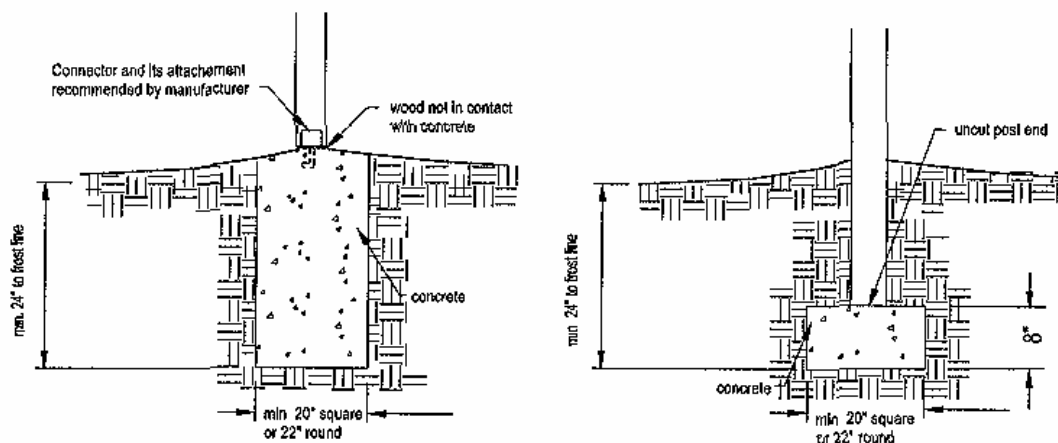

Figure 5: Typical footing details

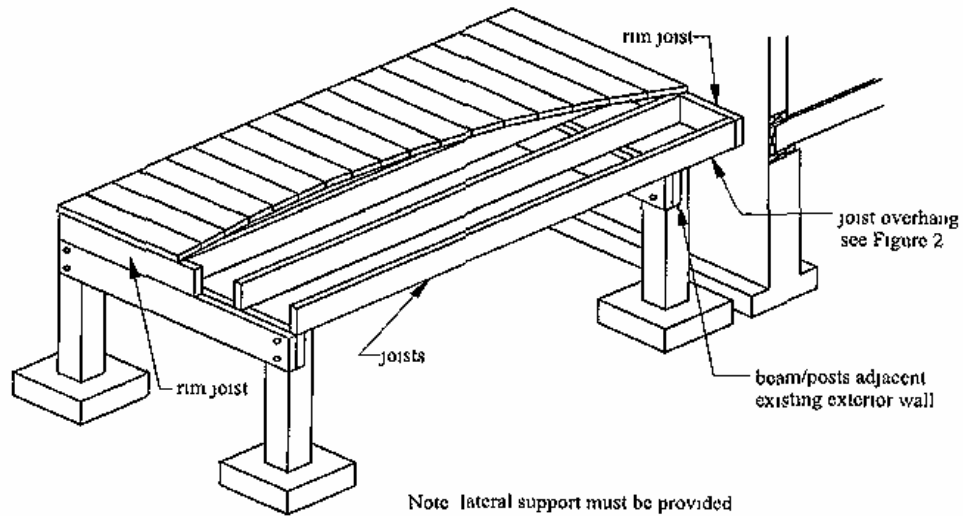

Figure 6: Freestanding deck

Attached Decks

Ledger board attachments to the exterior wall shall be constructed as indicated in Figure 7, Figure 8 and Figure 9. When required, flashing is not shown for clarity. These details are applicable for cases where there is no sheathing between ledger and band joist or engineered rim board but the lag screw is 1/2 inch shorter. **If the conditions at the house are not represented in this document, a plan submission is required or the deck must be freestanding.** It is assumed that the band joist and its connection to house are as strong as required to support the loads imposed by the deck.

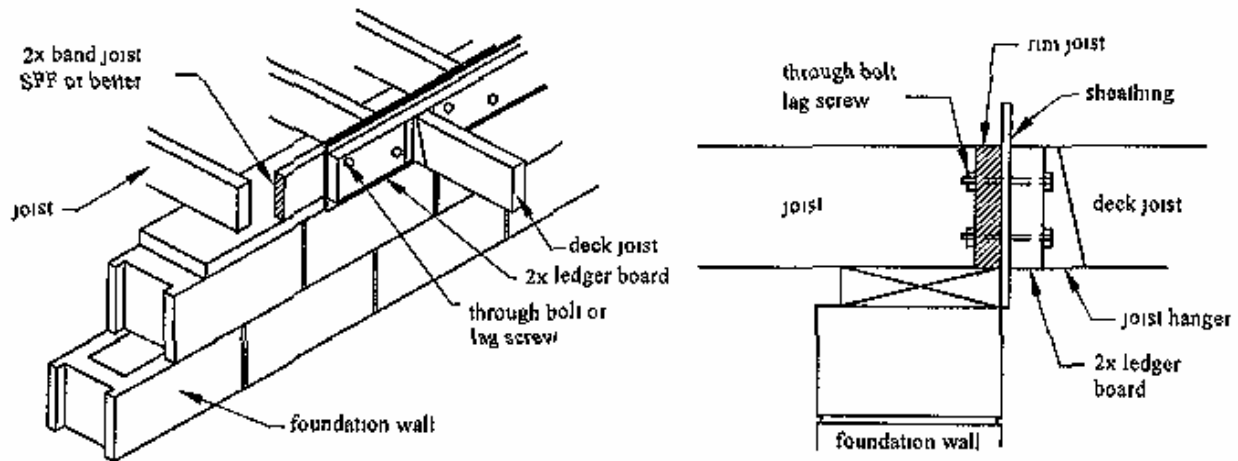

Figure 7: Deck attachment to single dimensional band joist

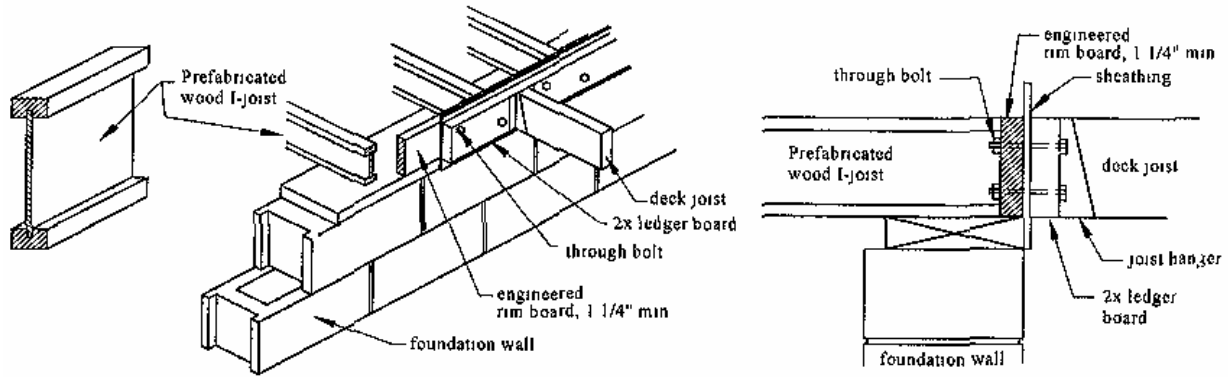
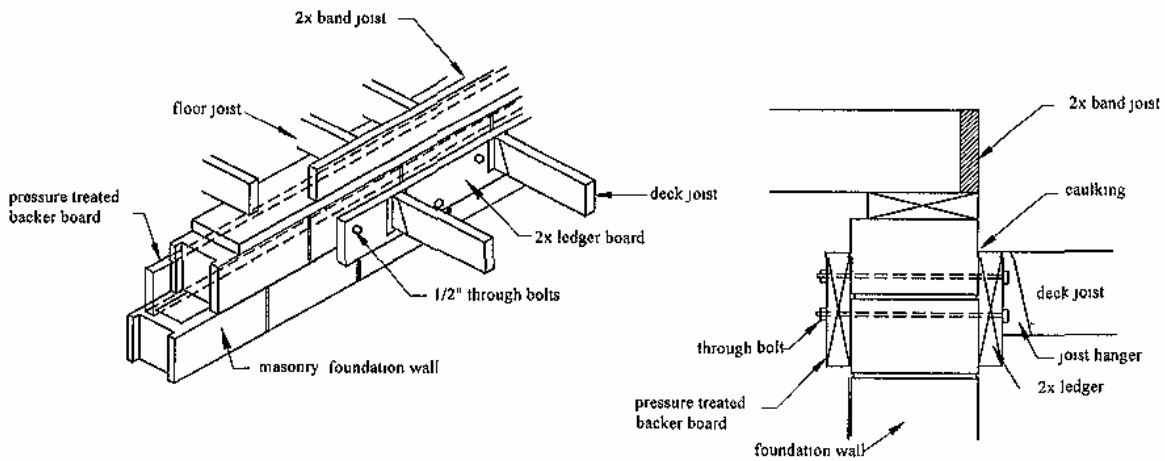

Figure 8: Deck attachment to engineered rim board



Note Do not use backer board on concrete walls
Use large washers on backer board or concrete walls

Figure 9: Deck attachment to hollow concrete masonry units foundation

Attachments to brick veneer (Figure 10), the ends of manufactured open web joists (Figure 11) and attachments to house overhangs/bay windows (Figure 12) are prohibited. **In such cases the deck shall be freestanding.**

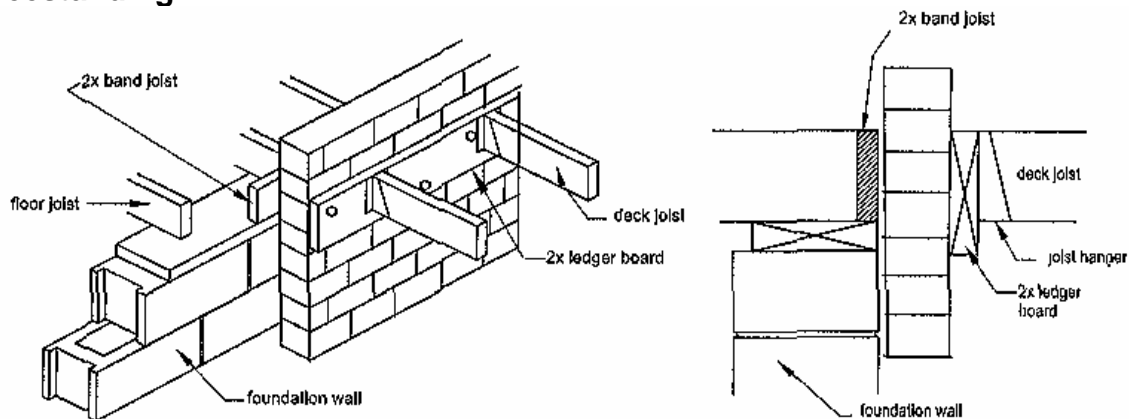

Figure 10: Deck attachment to brick veneer wall not allowed

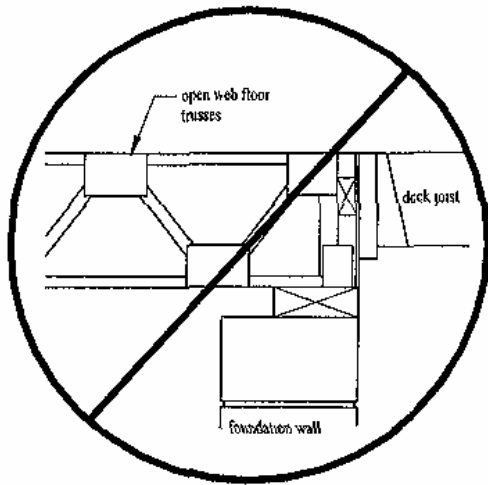

Figure 11: Attachments to open web trusses is prohibited

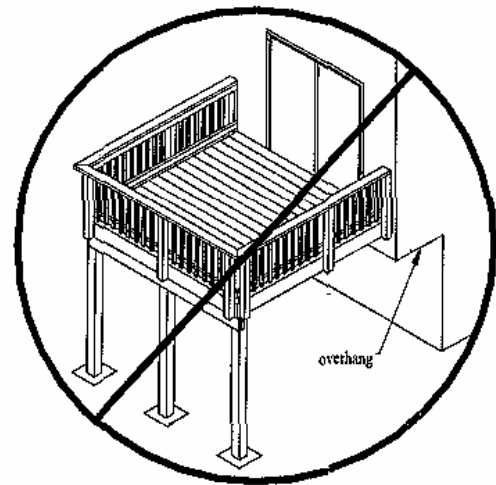

Figure 12: Attachment to house overhang is prohibited

When attaching the ledger to **single** band joists or **single** engineered rim board (Figure 7 and Figure 8), ½ inch diameter **lag screws** shall be installed with the spacing, S, shown in Figure 13, given in Table 2.

Pilot holes for the threaded portion of the lag screws shall be 40% to 70% of the shank diameter. All lag screws shall be installed with standard cut washers. The threaded portion of the lag screw shall be inserted into the lead hole by turning. Use soap or a wood-compatible lubricant to facilitate tightening. A test on the lag screw installation is recommended before the ledger attachment.

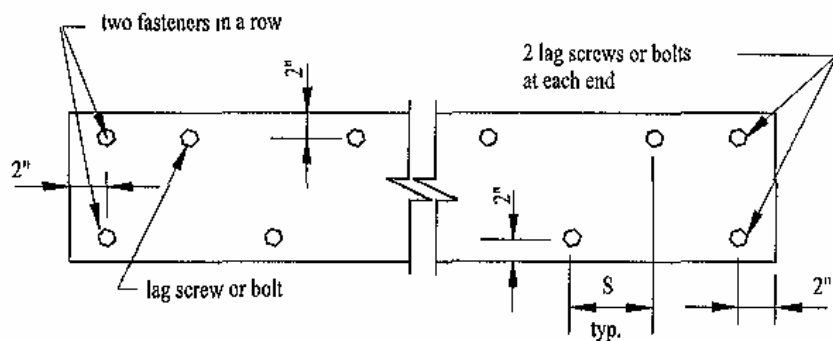

Figure 13: Placement of fasteners on ledger board

Table 2: Lag screws installed in single band joist

Number in a row	Size	Length in.	Max. spacing S – in.	Max. joist span - feet
1	1/2"	4	12	8
			9	10
			7	12
			6	14
			5	16
			5	18
4	20			

When attaching the ledger to **single** band joists (Figure 7, Figure 8 and Figure 9), ½ inch diameter **through bolts** can be installed instead of the lag bolts with the spacing, S, given in Table 3. Pilot bolt holes shall be drilled no more than 1/16 inch larger than the bolt diameter. All bolts shall be installed with standard cut washers under the head of the bolt and under the nut. **Carriage bolts are not acceptable.**



Through Bolts- acceptable to use



Carriage Bolts- NOT acceptable to use

Each bolt and lag screw shall be tightened, retightened after a year, and checked yearly thereafter. The preferred method of attachment is with bolts as it requires fewer penetrations and there is more control during installation.

Table 3: Through-bolts installed in single band joist, masonry or concrete foundation wall

Number in a row	Size	Length in.	Max. spacing S – in.	Max. joist span - feet
1	1/2"	As required	14	8
			13	10
			11	12
			9	14
			8	16
			8	18
			7	20

Flashing is required at any ledger board connection to a wall of wood frame construction. Flashing shall be corrosion resistant and shall be installed as shown in Figure 14 or as per manufacturer's recommendations.

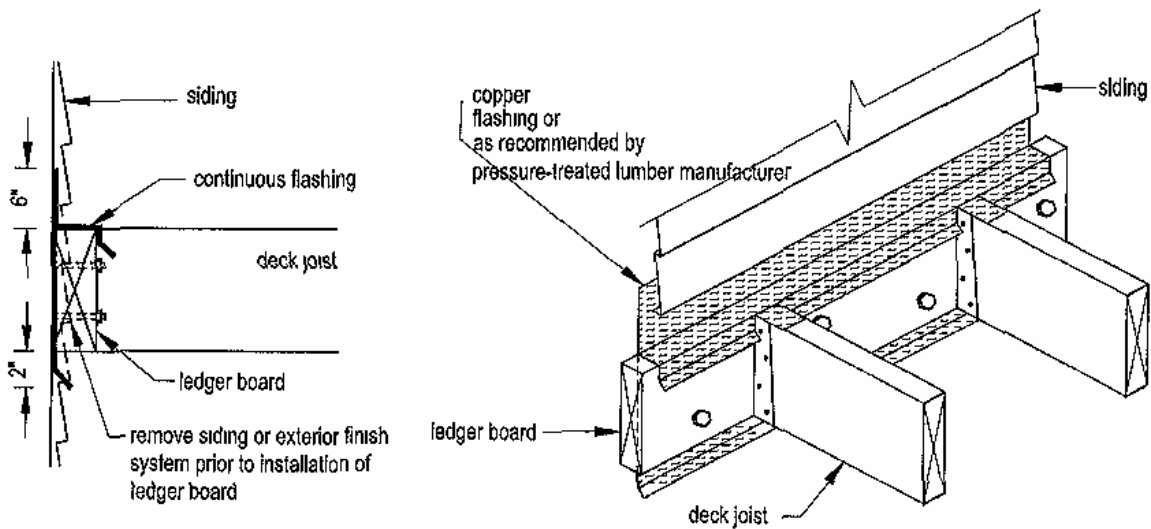

Note: Consult siding manufacturer for securing edges of siding to the wall

Figure 14: Flashing requirements

Decks that are up to 4 feet high above the ground do not need bracing. Decks that are above 4 feet, need bracing at least parallel to the house (Figure 4). Although posts can be set on concrete footings at the ground level or below ground (embedded posts) as shown in Figure 6, the latter solution is recommended for added deck stability.

Freestanding Decks

Freestanding decks regardless of height above ground shall resist vertical loading, lateral loading and movement by providing 6x6 inches posts and diagonal bracing as illustrated in Figure 15. It is recommended to embed the posts into soil to resist lateral loads and uplift. One set of diagonal bracing shall be located between posts and beams or parallel to the house. Another set of diagonal bracing shall be located perpendicular to beams and house in the end spans. This bracing shall be bolted to the post and joist above the post location. If the joist spacing is such that a joist does not align over a post location an extra joist shall be added to facilitate connection of the diagonal bracing.

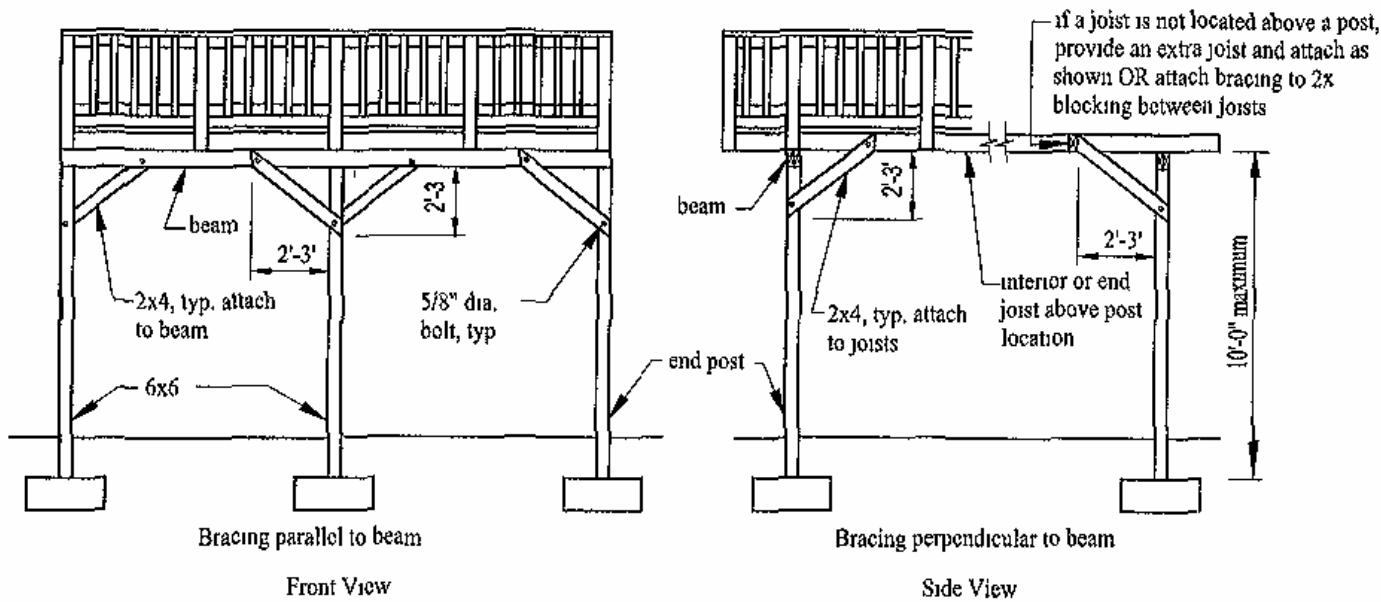

Note: Filler blocks may be required at the beams and joists
 Figure 15: Bracing for freestanding decks

Connections

When designing the connections, including ledger attachments, use a minimum number of fasteners.

I) Ledger to the house

See Attached Decks section.

II) Joist to beam

Each joist shall bear directly on the beam (Figure 16). Alternatively, different types of connectors or joist hangers compatible with the intended lumber and having a minimum capacity of 1000 pounds can be used (Figure 17).

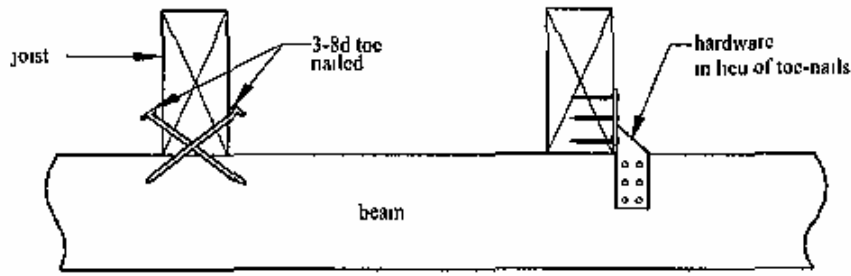

Figure 16: Joist to beam detail

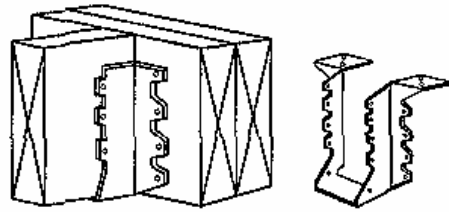

Figure 17: Joist to beam connection

III) Rim Joist to Joists

A continuous rim joist shall be attached to the ends of joists (Figure 18). Rim joists are required at both ends of joists with overhangs. Minimum rim joist dimensions shall be equal to those of the joists.

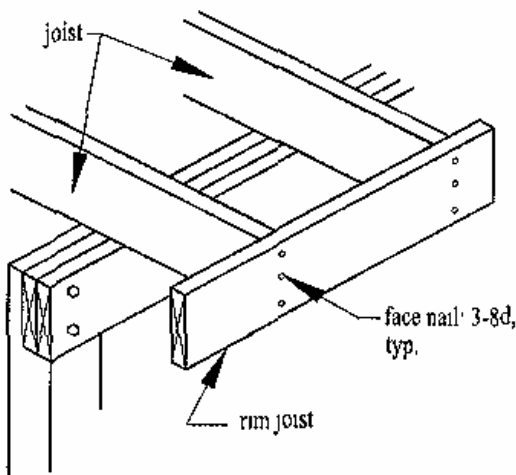

Figure 18: Rim joist connection

IV) Built-up beam

Built-up beams shall be assembled in accordance with Figure 19. For triple member beams, provide the nailing pattern shown to the outside member on each side; however staggered rows shall be offset so as not to occur in the same location.

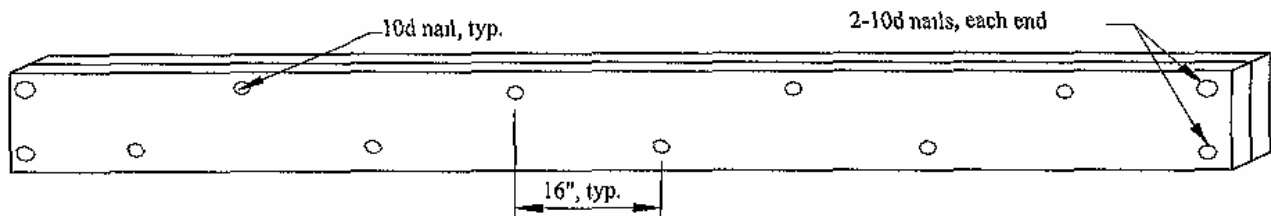

Figure 19: Built-up connection detail

V) Beam-to-post

Typical post-to-beam connections for 4x4 inches posts are shown in Figure 20. Same connection for 6x6 inches posts is shown in Figure 21.

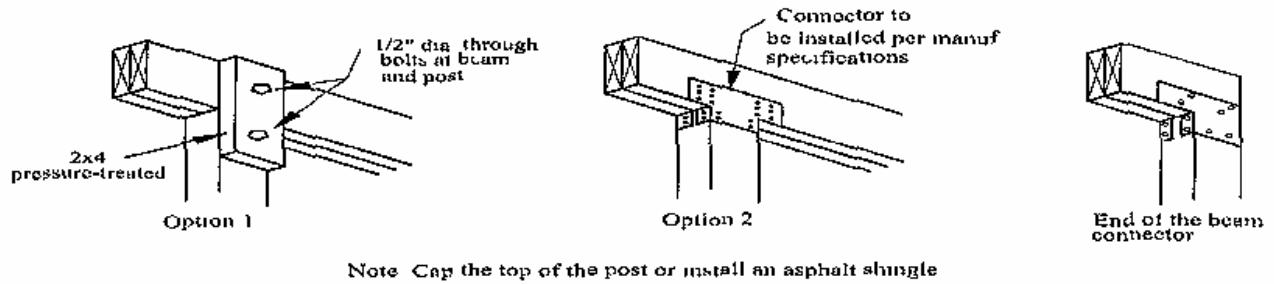

Figure 20: 4x4 inches post-to-beam connection

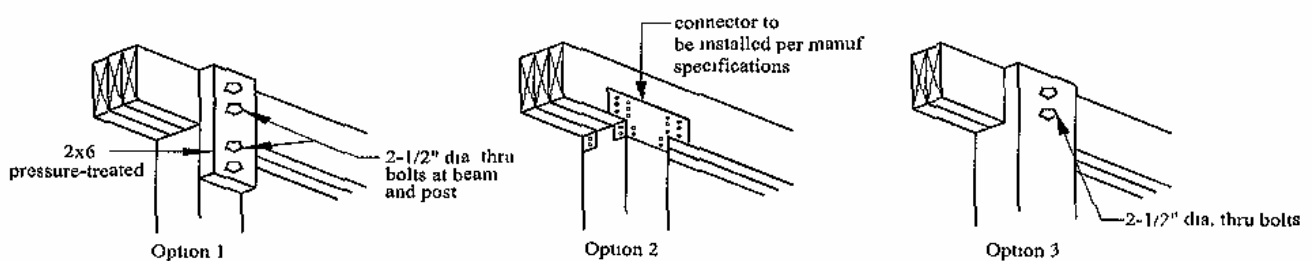

Figure 21: 6x6 inches post-to-beam connection

VI) Bracings

Two $\frac{3}{8}$ inch bolts shall be used at each connection between bracings posts, beams, and joists when 4x4 inches posts are used. One $\frac{5}{8}$ inch bolt shall be used at each connection between bracings posts, beams, and joists when 6x6 inches posts are used.

Guardrail Requirements

Guardrails shall be constructed as shown in Figure 22 and Figure 23. The guardrail posts can be attached to the exterior of the rim joist (Figure 24), or the interior of the rim joists (Figure 25). Installation of the through bolts and lag bolts follow same rules as outlined above. Lag bolts can be replaced with connectors installed at the top and bottom of joists - such a hurricane ties capable to withstand 600 pounds per tie. A manufactured guardrail system requires a construction plan submission accompanied by a product specific evaluation report that is currently listed with an approved code agency.

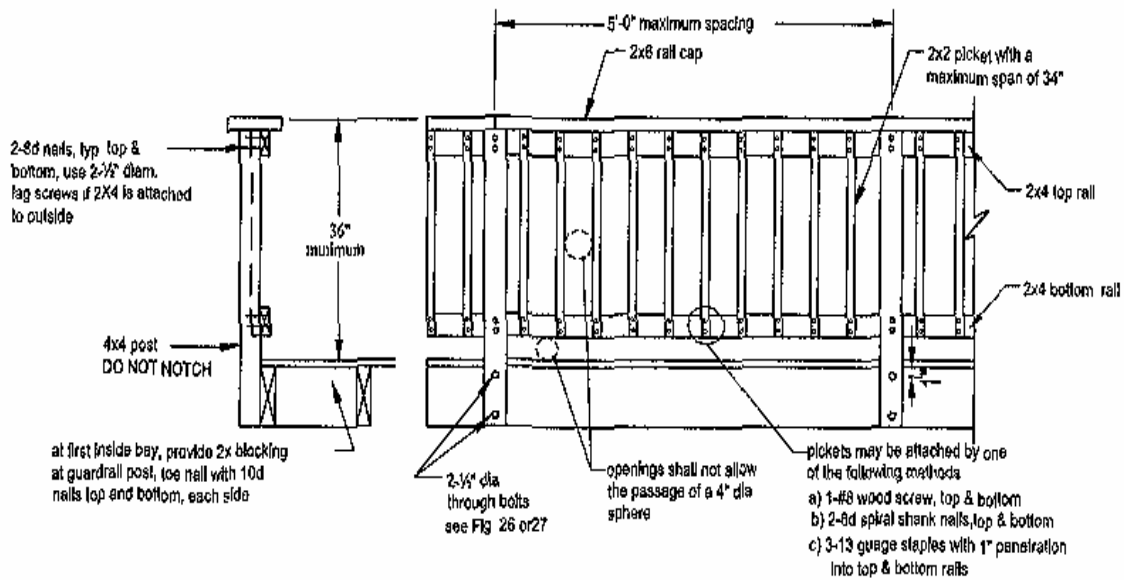

Figure 22: Typical guardrail details

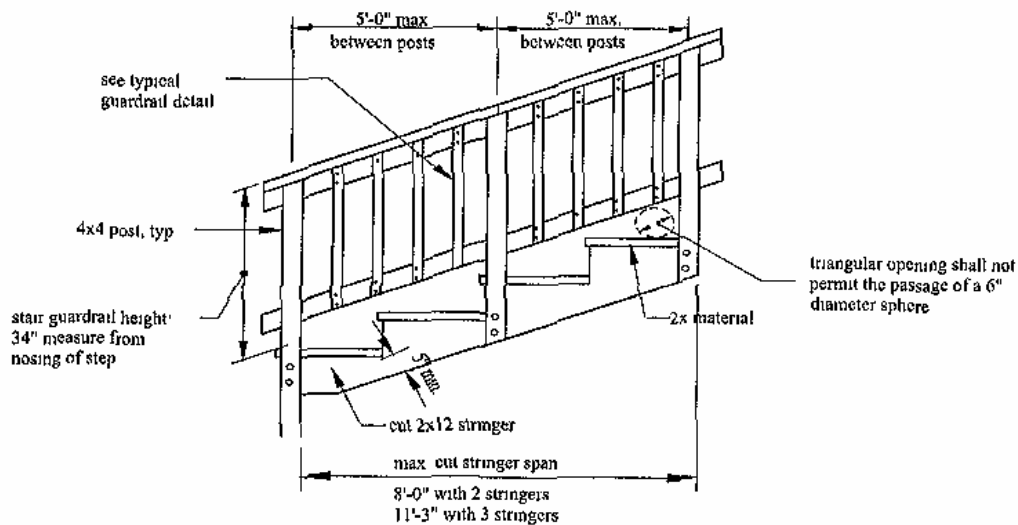

Figure 23: Guardrail and cut stringer detail

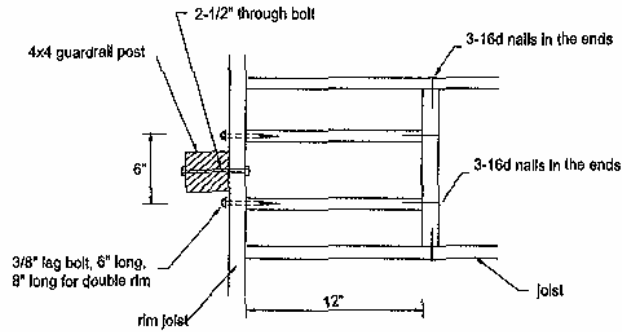

Figure 24: Plan (top) view-Exterior guardrail post

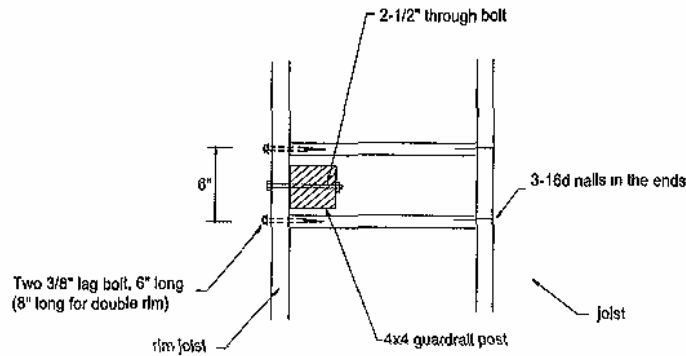

Figure 25: Plan (top) view-Interior guardrail post

Stair Requirements

Stairs shall meet the requirements shown in Figure 26, Figure 27 and Figure 28. All stairs shall be provided with an artificial light source which will illuminate the stair including all treads and risers.

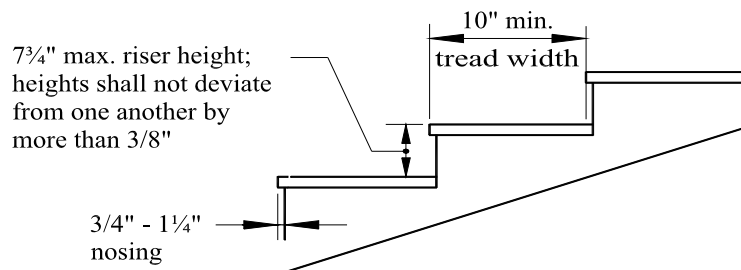

Figure 26: Tread and riser detail

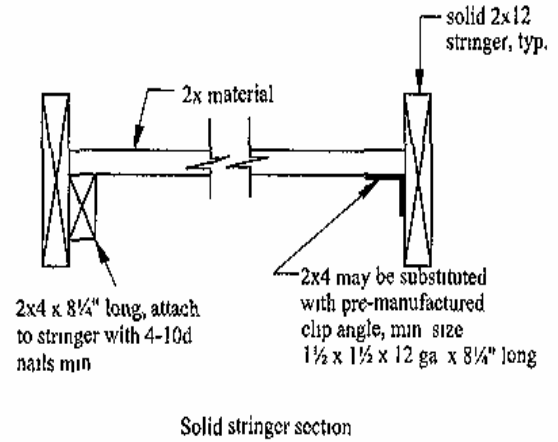
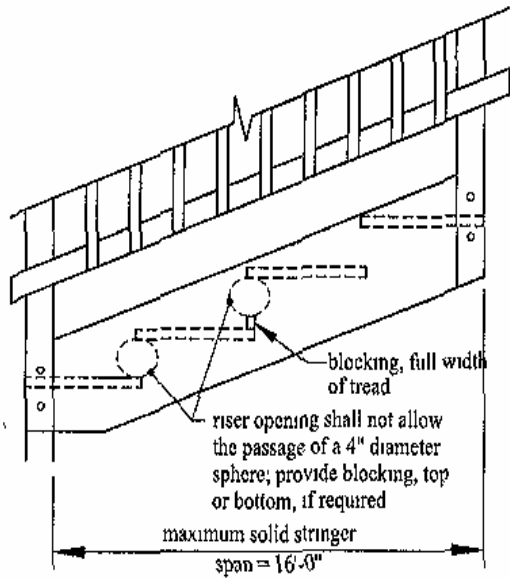
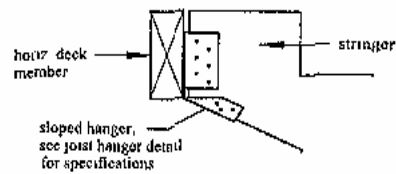
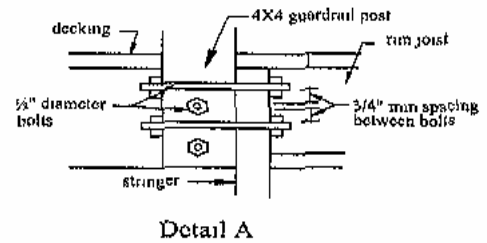
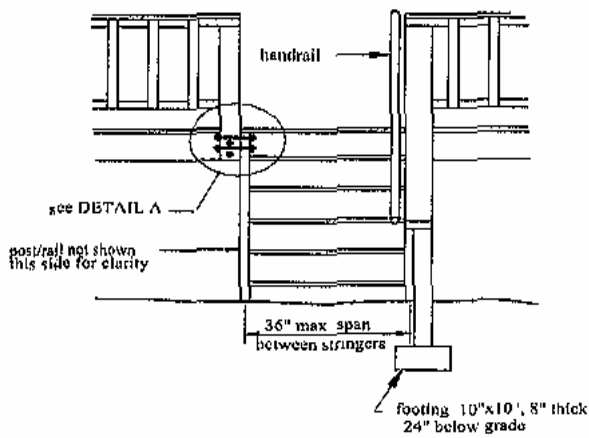

Figure 27: Solid stair stringer detail



Alternate attachment

Figure 28: Stair connection requirements

Handrail

All stairs with two or more risers shall have a handrail on one side. Handrails shall be graspable and shall be composed of decay-resistant and/or corrosion resistant material. The hand grip portion shall be between $1\frac{1}{4}$ inches and $2\frac{5}{8}$ inches diameter or the shape shall provide an equivalent smooth gripping surface with no sharp corners (Figure 29).

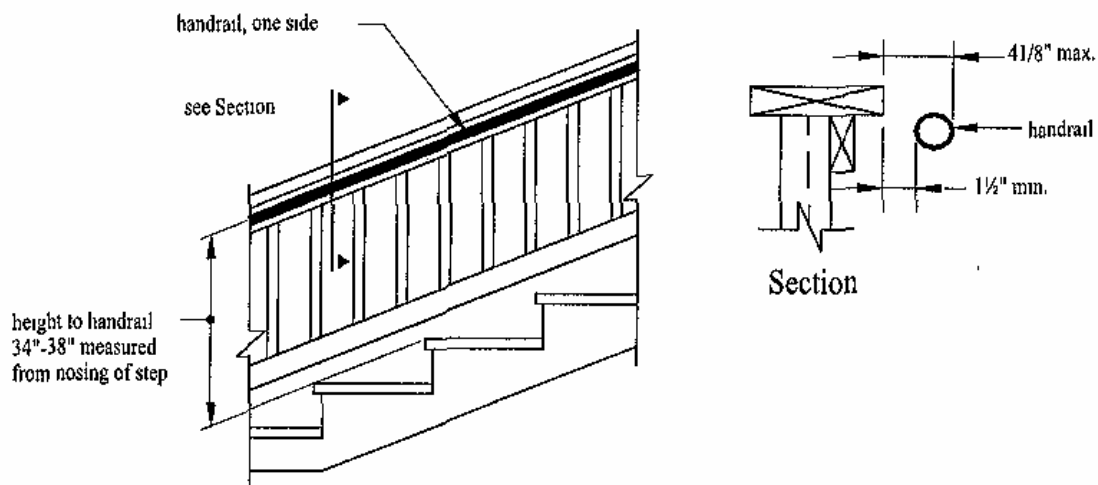

Figure 29: Stair handrail detail

Electrical Requirements

210.8 Ground-Fault Circuit-Interrupter Protection for Personnel.

3) Outdoors

Exception to (3): *Receptacles that are not readily accessible and are supplied by a dedicated branch circuit for electric snow-melting or deicing equipment shall be permitted to be installed in accordance with [426.28](#).*

210.52 Dwelling Unit Receptacle Outlets.

(3) Balconies, Decks, and Porches. Balconies, decks, and porches that are accessible from inside the dwelling unit shall have at least one receptacle outlet installed within the perimeter of the balcony, deck, or porch. The receptacle shall not be located more than 2.0 m (6 ft) above the balcony, deck, or porch surface.

Exception to (3): *Balconies, decks, or porches with a usable area of less than 1.86 m² (20 ft²) are not required to have a receptacle installed.*